

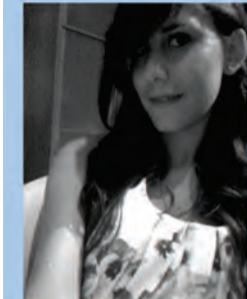

Valentina Sapio



Antonietta Esposito



Aurelia Federica Amatucci

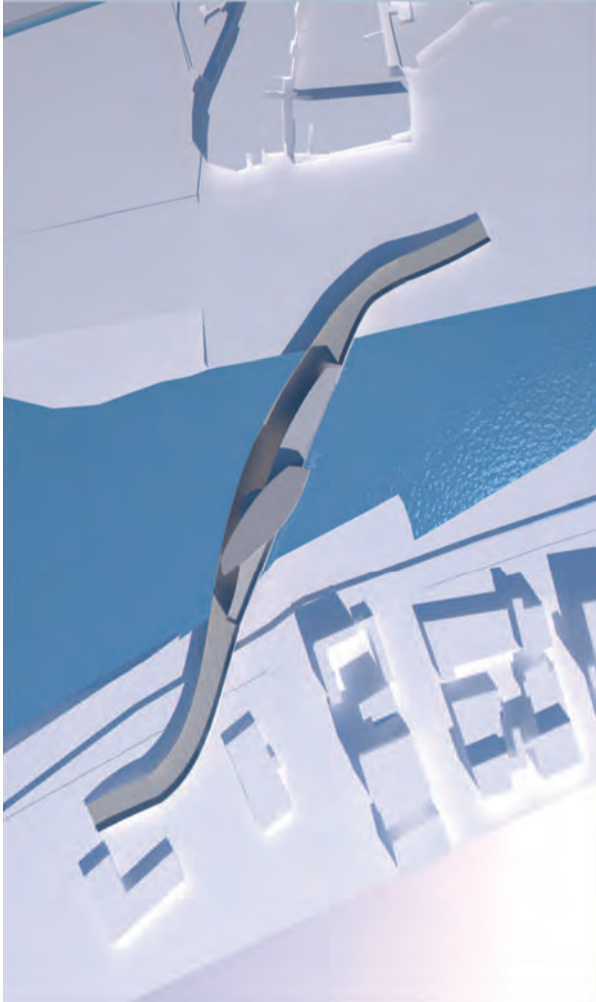

DARDANUS MUSEUM  
The title "Dardanus" chosen for our project derives from the name of Canakkale's city in Greek era. The proposal comes from the intention of creating a building able to interact appropriately with the surrounding space and, at the same time, able to become an attraction both for local people and tourists. The building has two floors: on the ground floor there are the common spaces, such as the hall, the cloakroom, the exhibition area, the book shop and the meeting area while on the first floor we place the bar and the restaurant. The structure has been conceived to connect the two shores through an external path that, on the only one side, "wraps up" the building designed for the museum of ceramics.

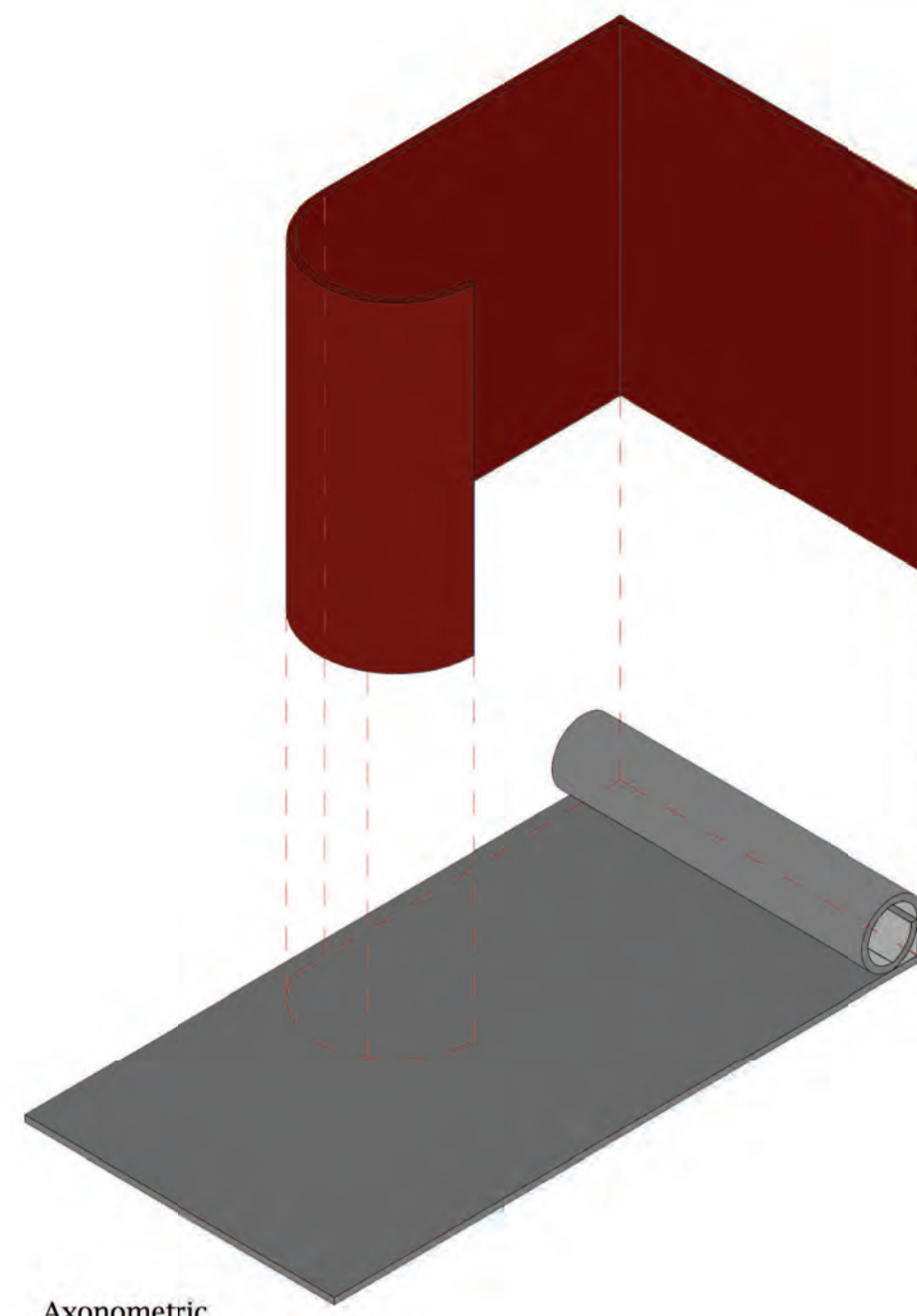
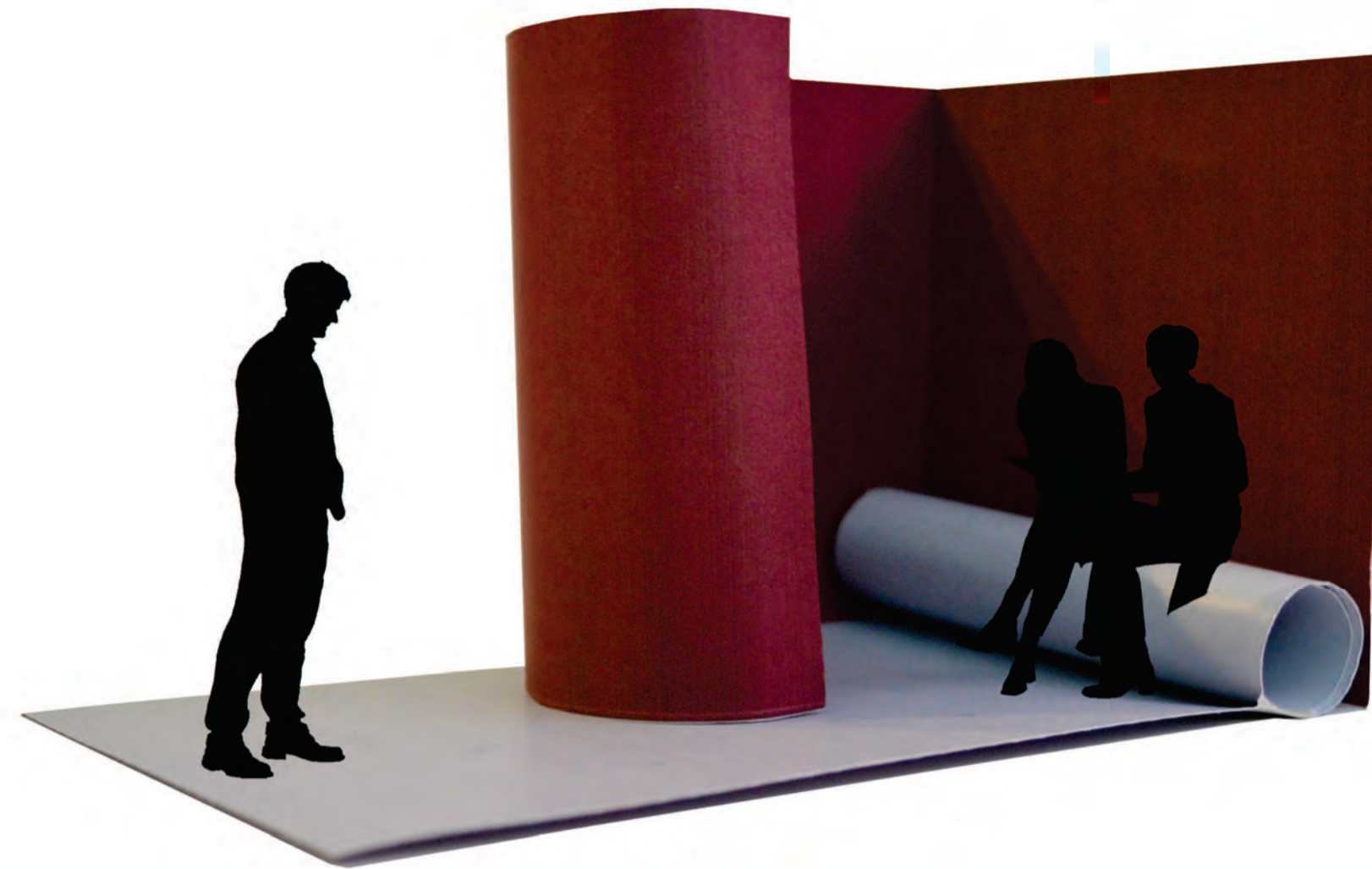
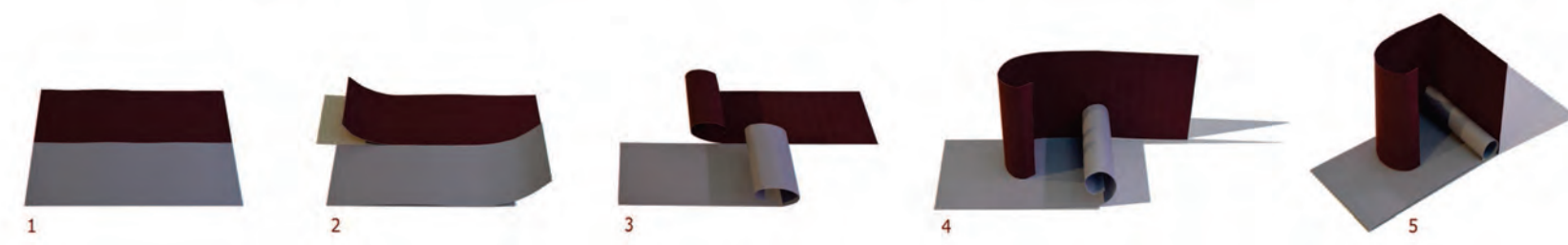

Axonometric

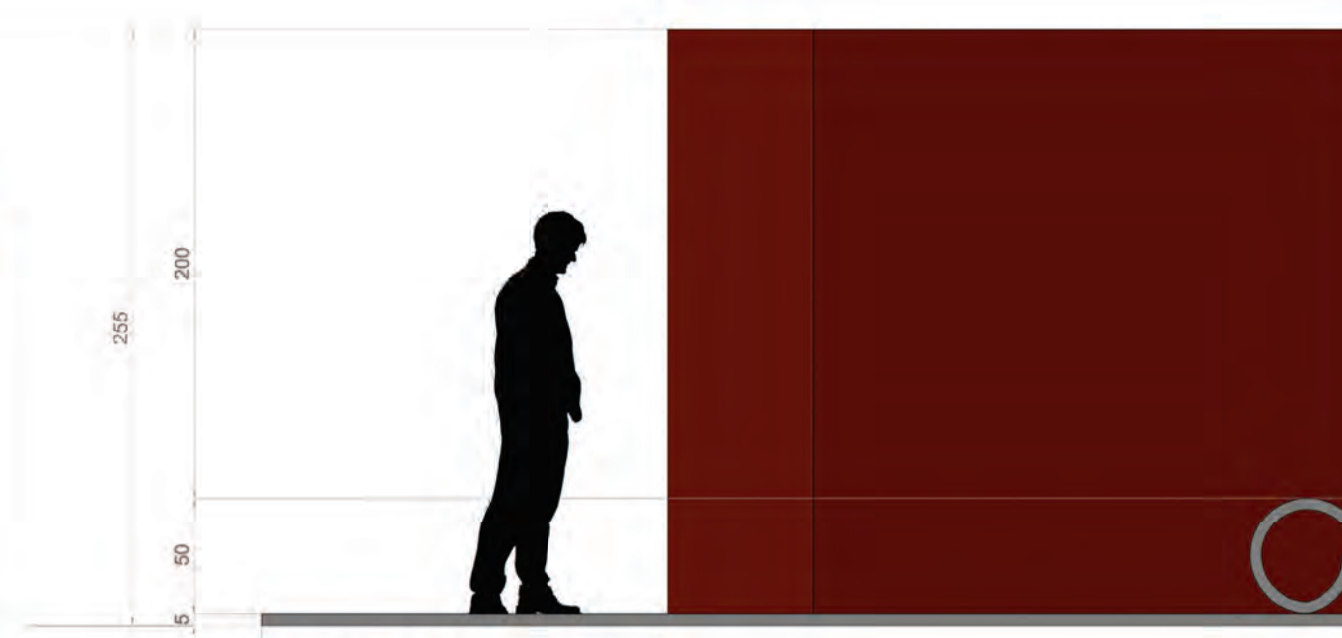

Front view B

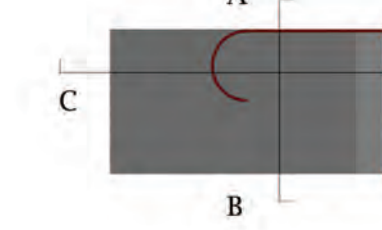

Section D



Top View

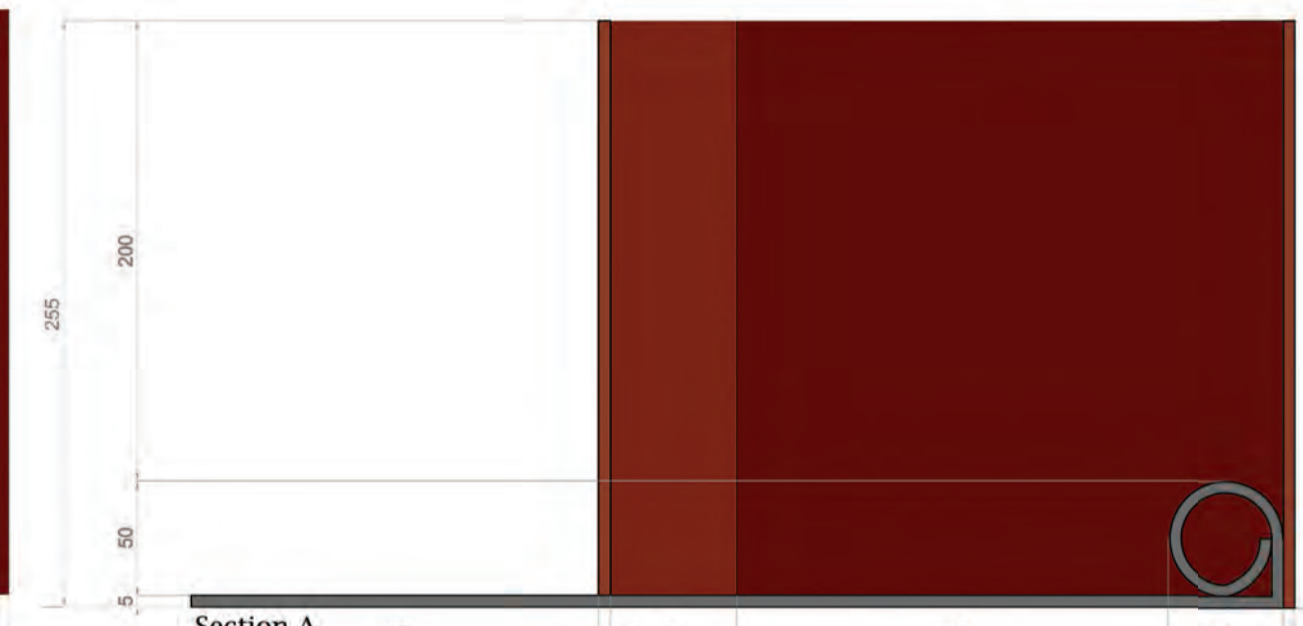

Section A

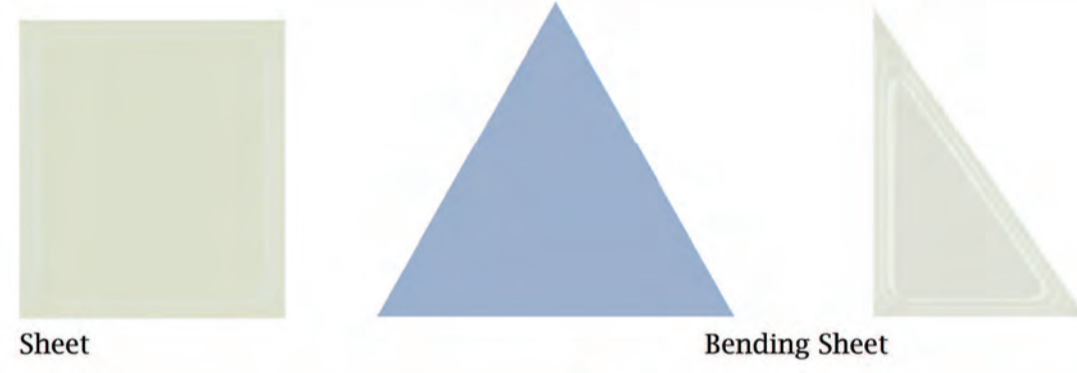

Sheet

Bending Sheet

ORIGAMI LAMP

Through the triangle in bending of a single sheet of paper, I got a form that suggested to me a lamp.

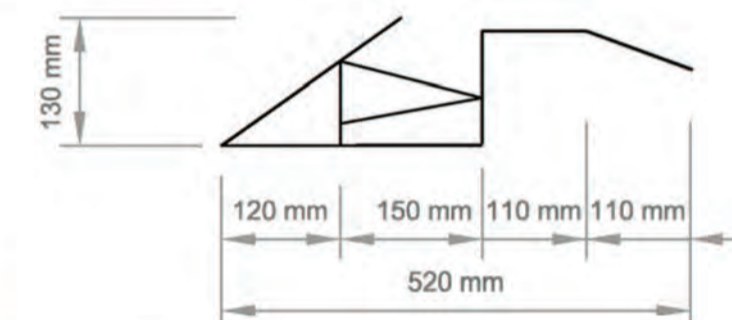
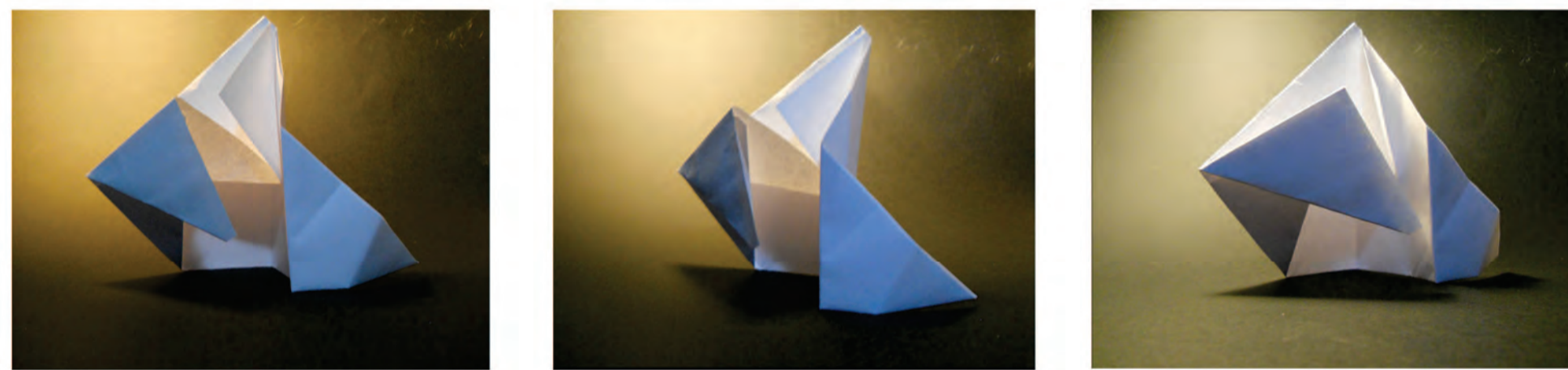

Top View

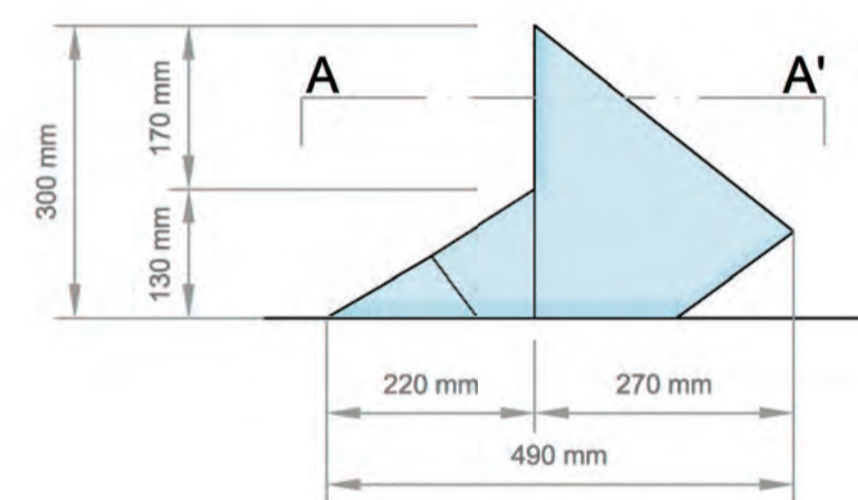

Back View

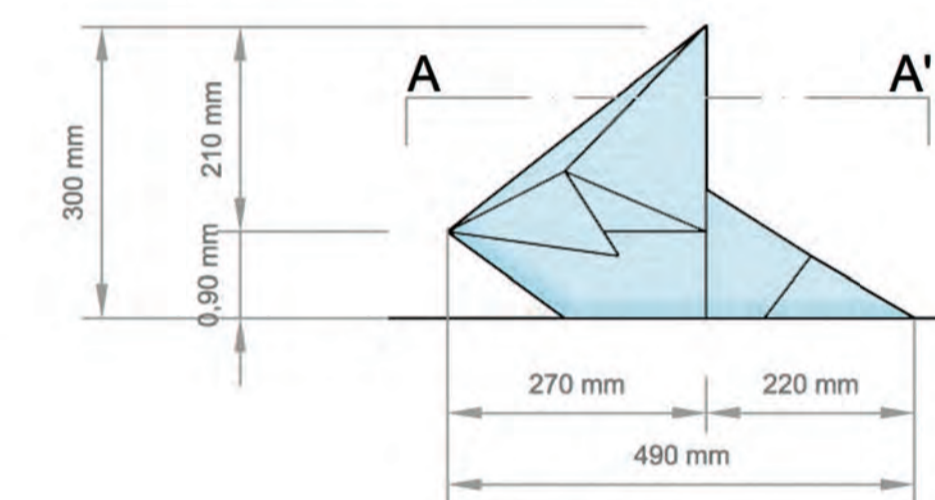

Front View

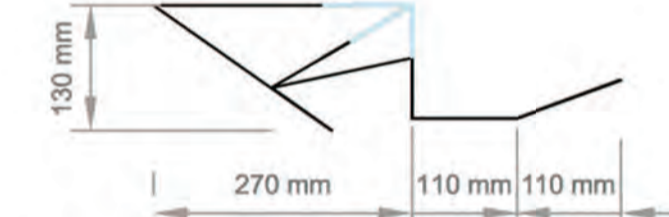

Section A-A'

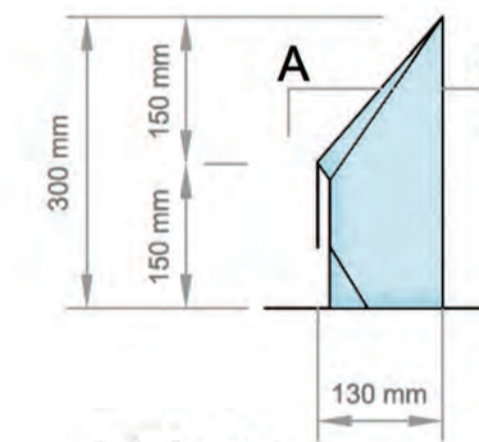

Right Side View

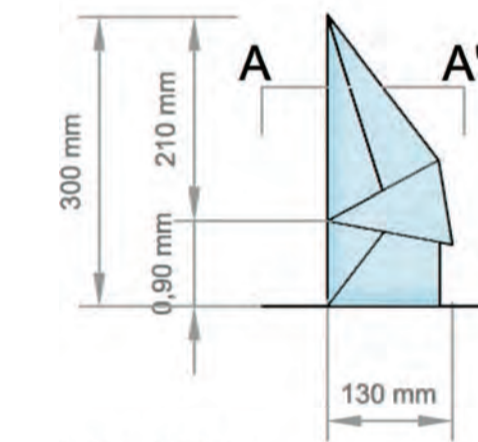

Left Side View

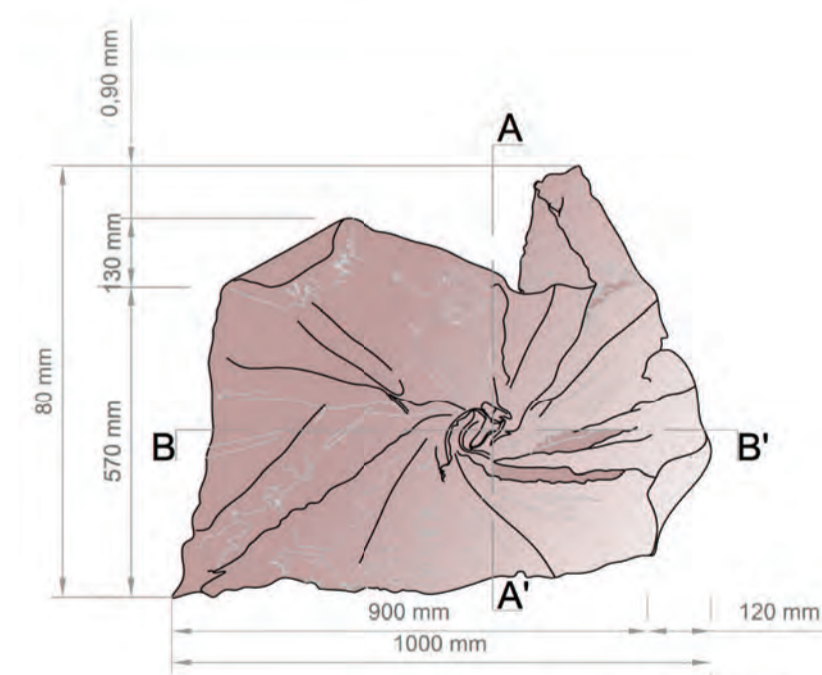
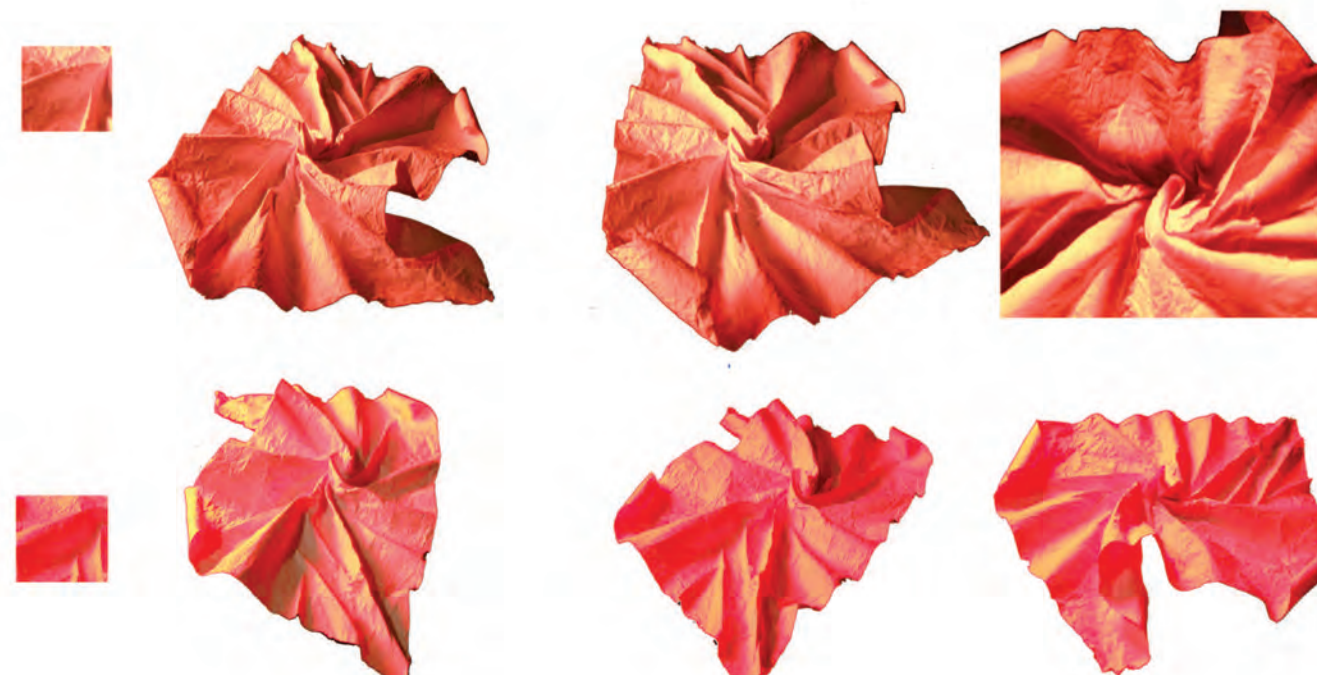
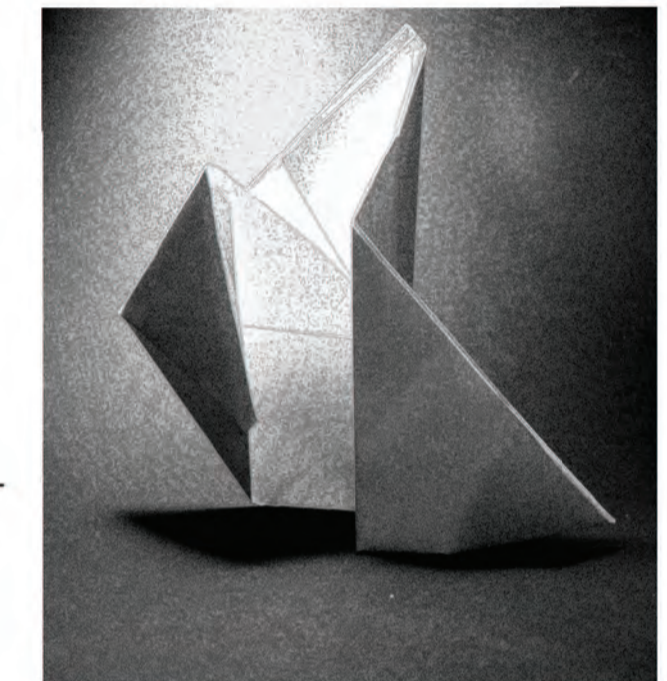

Front view

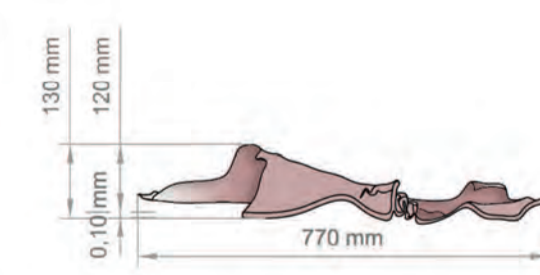

Section A-A'

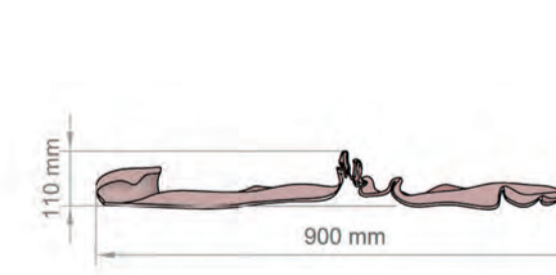

Section B-B'

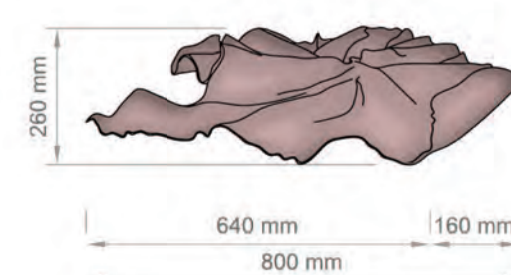

Left Side View

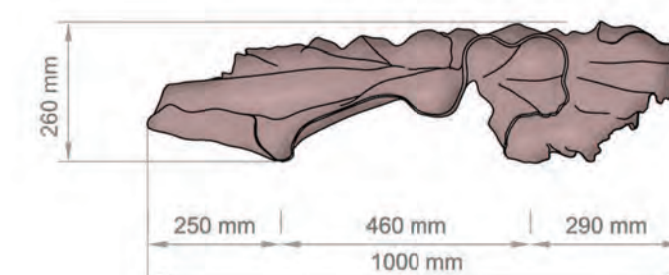

Top view

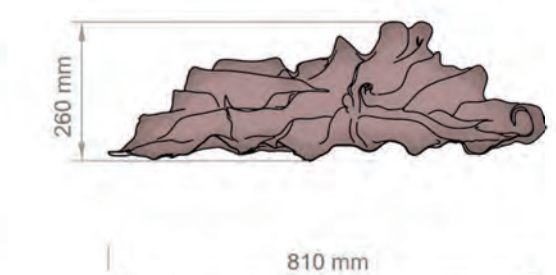

Right side view

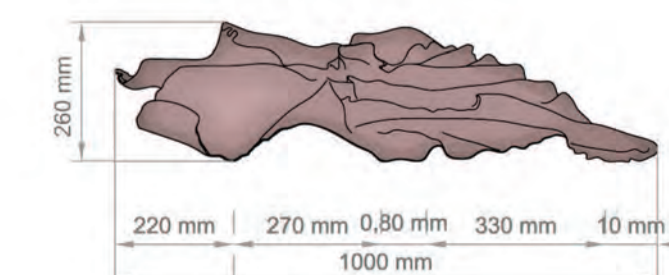

Bottom View

